

Pfi



SR4 - STAGE TWO

SPRINGS ROAD ESTATE.



OVERVIEW.

WAREHOUSE AREA

4,770 SQM

TARGETED AVAILABILITY

Q1 2026

SUSTAINABILITY TARGET

5 STAR GREEN STAR

SPRINGS ROAD ESTATE.

NEXT GENERATION INDUSTRIAL

PFI's Springs Road Estate is located within Auckland's East Tāmaki. Set on 10.4 hectares with high profile road frontage, the site's multi stage redevelopment delivers world class, sustainable facilities designed to optimise your industrial operations.

BUILT FOR SUCCESS

Tenants of Springs Road Estate enjoy the benefits of brand new buildings in a well-established industrial precinct, supported by robust infrastructure and a thriving business community. With proximity to key amenities and transport links, Springs Road Estate combines strategic positioning, modern design, and long-term value for your business.



LOCATION THAT DELIVERS.

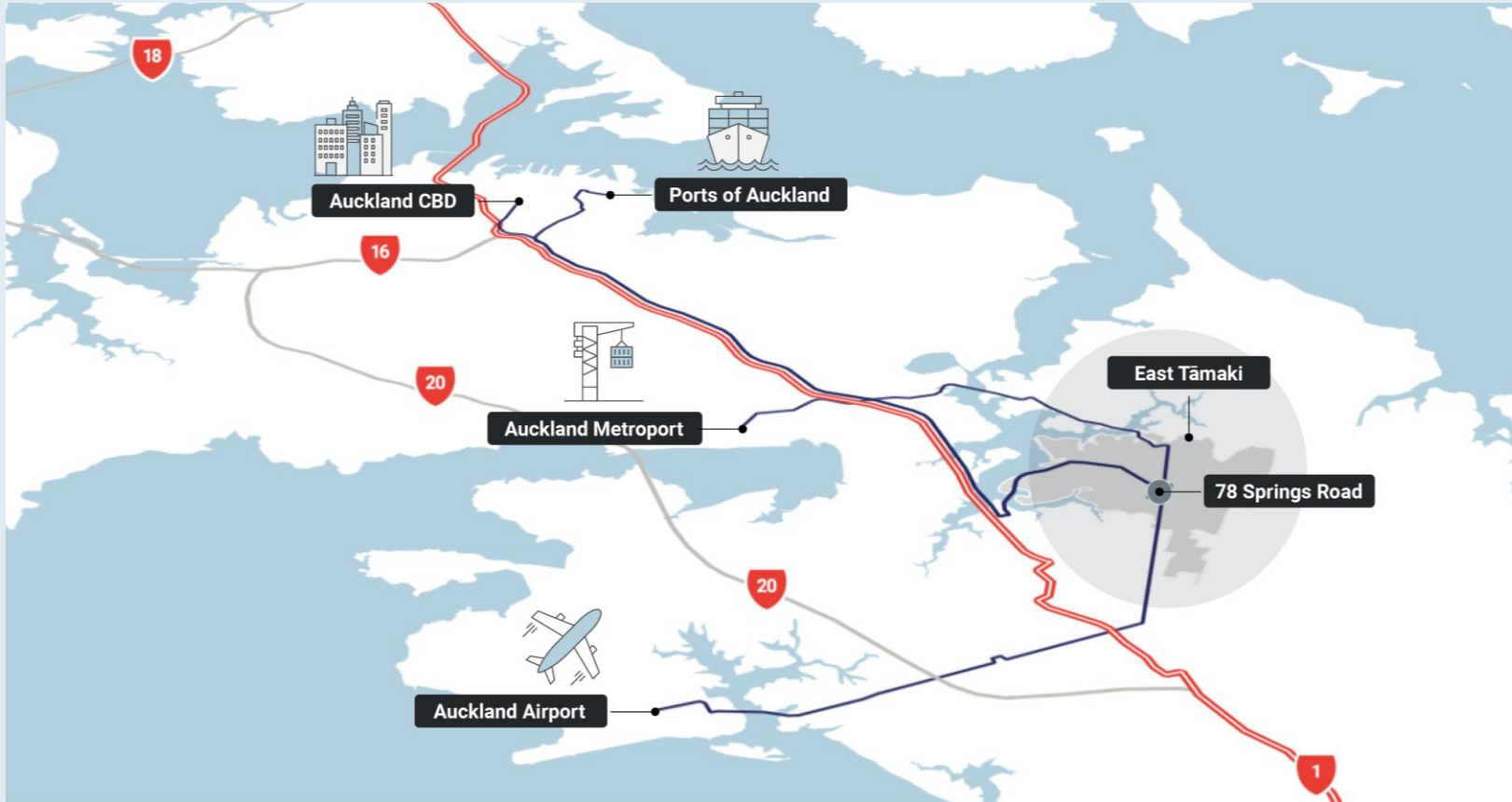

PRIME POSITION IN EAST TĀMAKI

Springs Road Estate is located at 78 Springs Road, right in the heart of East Tāmaki—Auckland’s leading industrial area. The estate enjoys prominent road frontage to both Springs Road and Kerwyn Avenue, offering excellent visibility and easy access for businesses and visitors.

EFFICIENT TRAFFIC FLOW AND LOGISTICS

The estate’s location allows businesses to avoid central city congestion, with routes designed for smooth traffic flow and reliable logistics. Its proximity to major transport infrastructure ensures fast, efficient access for deliveries and distribution.

**GREATER
AUCKLAND
DRIVE TIMES***



**20
MINS**
AUCKLAND
AIRPORT



**16
MINS**
AUCKLAND
METROPORT



**22
MINS**
AUCKLAND
CBD



**24
MINS**
PORTS OF
AUCKLAND

*Dependent on traffic

STRATEGICALLY CONNECTED.

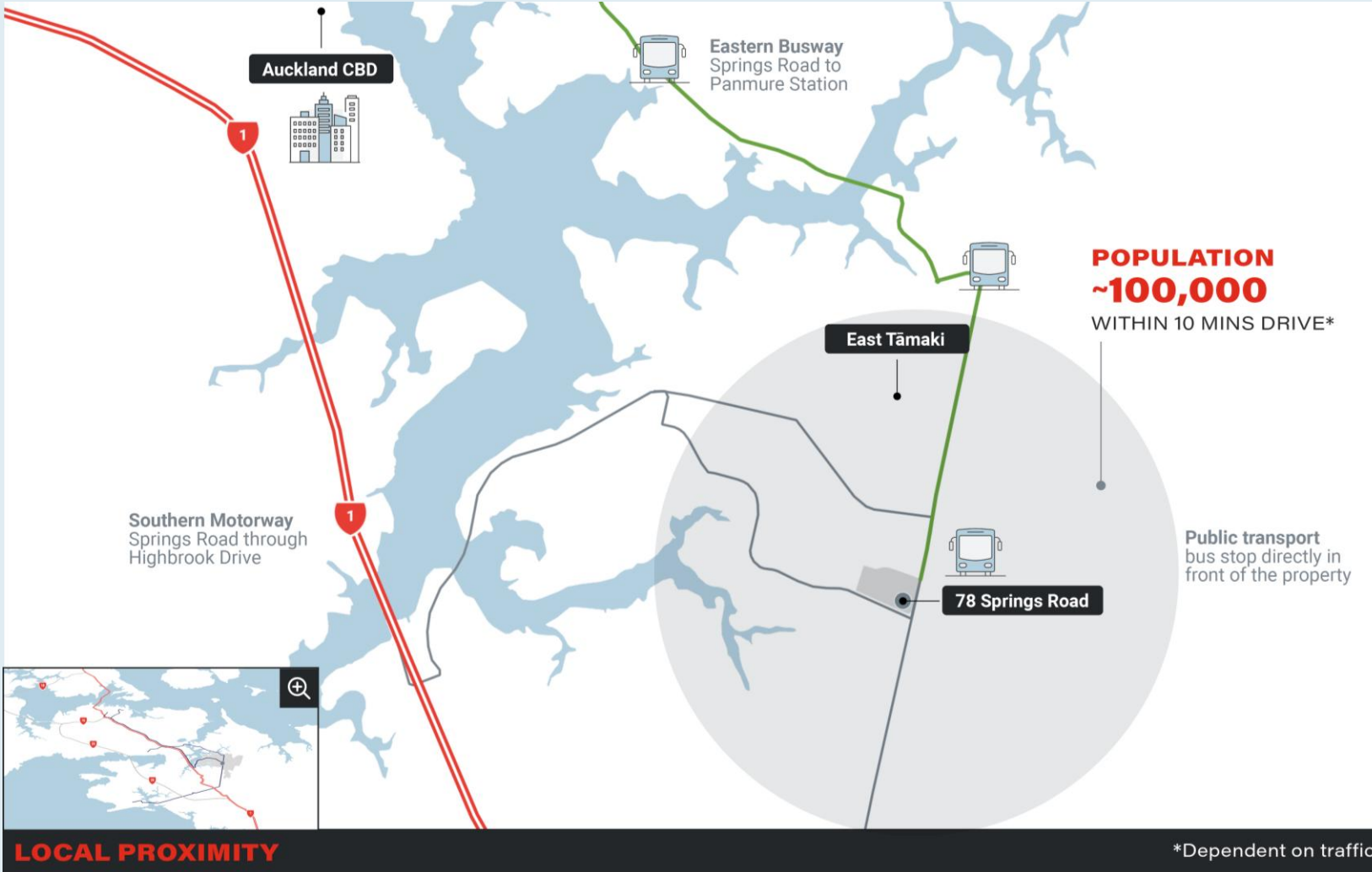

CONVENIENT PUBLIC TRANSPORT LINKS

Spring Road Estate benefits from strong public transport options, with a bus stop located directly outside the site. This makes commuting straightforward for staff and visitors, supporting workforce accessibility.

DIRECT ACCESS TO KEY TRANSPORT ROUTES

The estate is strategically positioned close to the Southern Motorway and major arterial roads, streamlining freight movement and daily commuting. This location enables efficient connections across Auckland and to wider regional markets.

KEY FEATURES.

AVAILABLE:

Q1 2026 – Targeted practical completion.

OVERVIEW:

Warehouse SR4 of our premium Springs Road Estate industrial development offers a high-quality, sustainable facility with modern amenities. Situated in Auckland’s East Tāmaki, this warehouse is well located for connectivity to the city’s highway and freight networks.

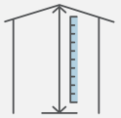

HIGH-STUD
(~12.5m TO THE KNEE)



**FIBRE-REINFORCED
CONCRETE SLAB**
35 MPA STRENGTH

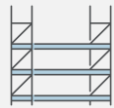

PALLET CAPACITY
STANDARD - 8,230
VNA – 10,506



**FULL DRIVE
AROUND ACCESS**

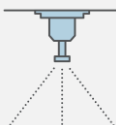

**FULLY SPRINKLERED
BUILDING**



**GREEN STAR
DESIGN & AS BUILT RATING**



YOUR BUILDING LAYOUT.

WAREHOUSE	4,770sqm
OFFICE	400sqm
CANOPY	1,030sqm
YARD	900sqm
CARPARKS	32

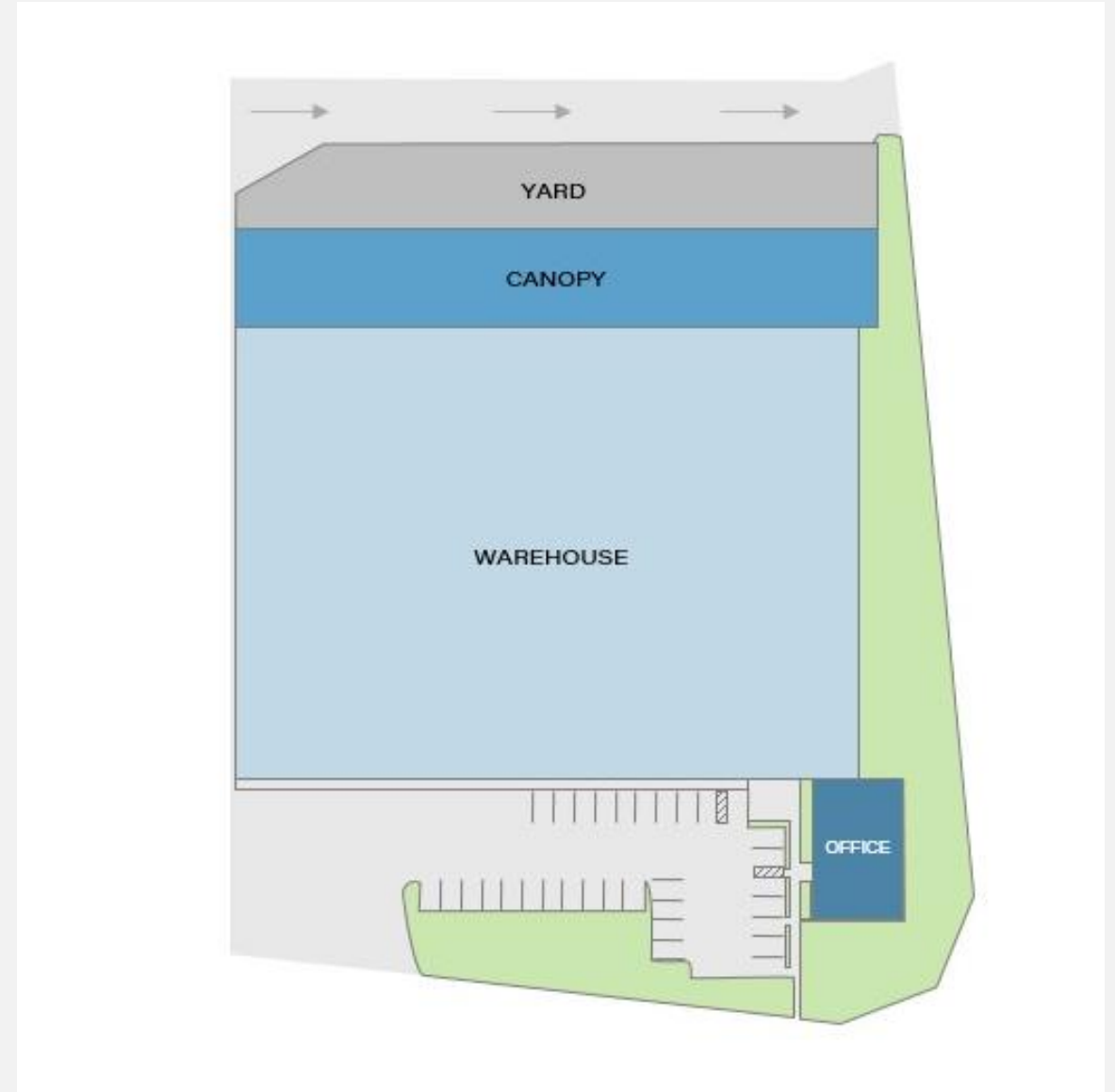
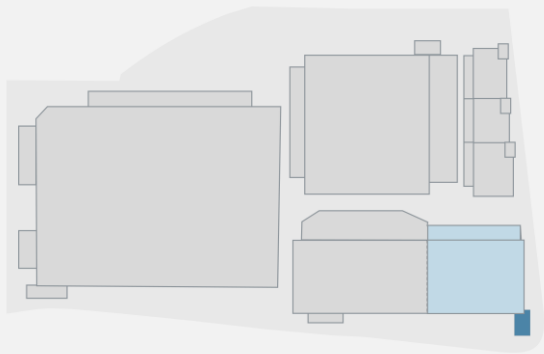

*Warehouse Office and Showroom options available

DEVELOPMENT TIMELINE.



**DESIGN AND
CONSENTING**

Q4 2024



**SITE
POSSESSION**

Q1 2025



**PLANNED EARLY
TENANT ACCESS**

Q1 2026



**PLANNED PRACTICAL
COMPLETION**

Q1 2026

BUILT FOR A GREENER FUTURE.

Choosing a property within a new PFI estate means committing to sustainability from the ground up. Each development targets a 5 Star Green Star Design & As Built rating - delivering energy efficiency, reduced operational costs, and a healthier environment for tenants and their teams.



WHAT GREEN STAR MEANS

- New Zealand's leading sustainability rating system for buildings
- Measures performance across energy, water, materials and indoor environment quality
- Creates healthier, more efficient spaces for people and businesses



WHY WE DO IT

- Lower operational costs for tenants through energy and water efficiency
- Healthier workplaces with improved air quality and natural light
- Reduced environmental impact from construction and operation

DESIGNED FOR PERFORMANCE AND WELLBEING.

Every significant new PFI development integrates features that support efficiency, comfort, and environmental responsibility.

At Springs Road Estate, this starts with sustainable construction choices such as low-GWP concrete and a target of at least 70% waste diversion from landfill.

The design includes energy and water efficiency measures and careful attention to indoor environment quality, with fresh air rates 100% above NZBC requirements, low ambient noise, good access to daylight and views, and LED lighting for uniform, flicker-free illumination.

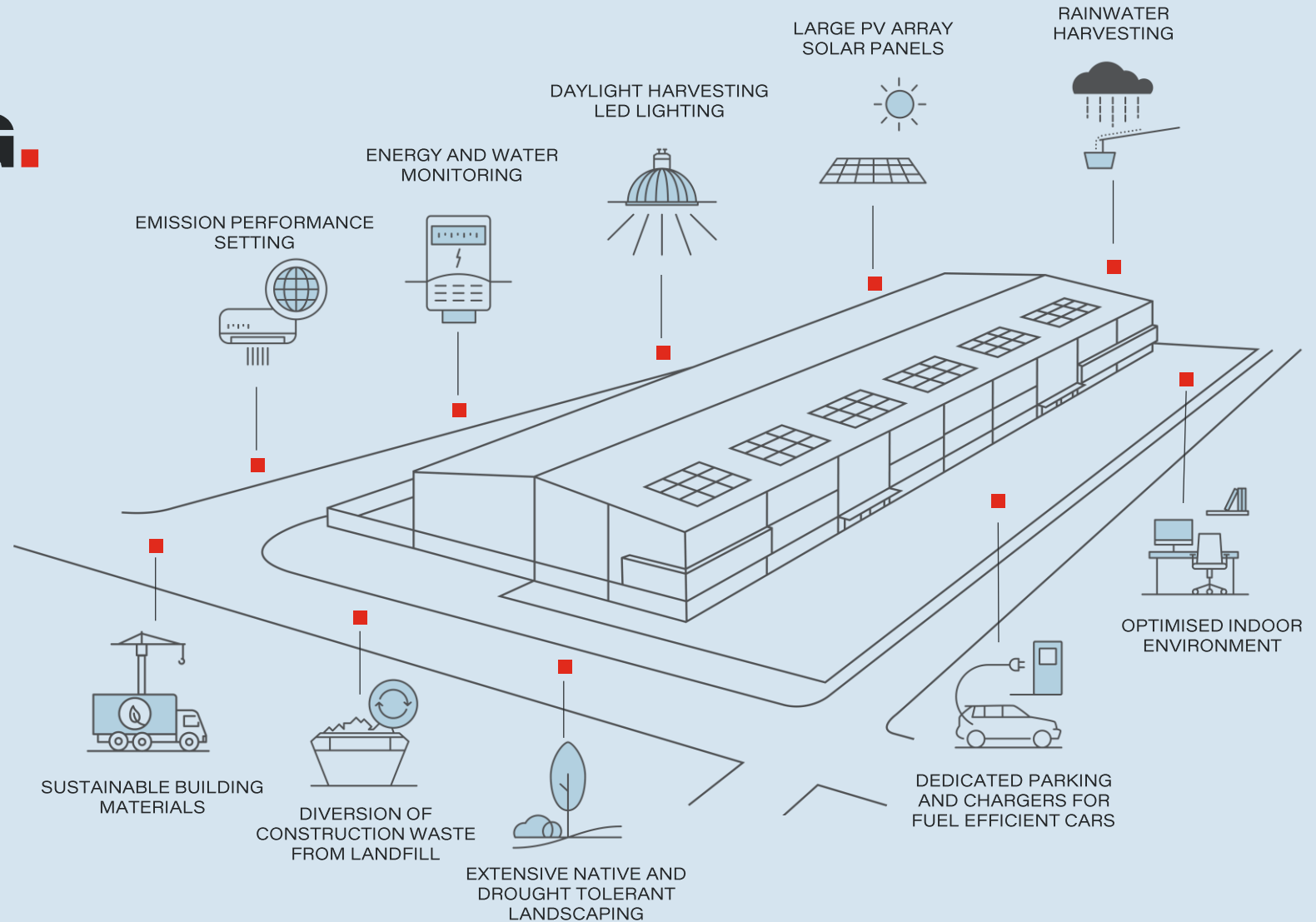

ABOUT PFI.

ELEVATING INDUSTRY, SUSTAINING SUCCESS

PFI is an NZX listed industrial property specialist, owning over 90 quality properties worth more than \$2 billion. Our well diversified portfolio is focused on strategic locations that drive value and growth for the industrial sector, for our tenants, and for our investors.

Since listing on the NZX in 1994, we've built a strong track record of delivering consistent returns. We invest for the long-term, combining our capital and specialist industry capability to deliver the successful outcomes all our stakeholders need.



94
PROPERTIES

125
TENANTS

99.9%
OCCUPANCY

\$2.25b
PORTFOLIO
VALUATION

All numbers presented as at 24 February 2026

PROVEN DEVELOPMENT EXPERTISE.



AWARD-WINNING DELIVERY

All of our recent 5 Star Green Star design developments were delivered on or ahead of time and budget—demonstrating our ability to deliver high-quality, sustainable industrial spaces.

TRUSTED PARTNERSHIPS

We work with a network of trusted, reputable contractors to ensure quality, reliability, and smooth delivery throughout the development process.



MORE THAN JUST A LANDLORD.

TAILORED, AGILE SUPPORT

We move fast, so your business doesn't have to slow down. With the resources to support fit-outs, extensions, or custom features, we adapt spaces efficiently—keeping your operations agile and uninterrupted.

CONNECTED PARTNERSHIPS

We take time to understand your needs and deliver tailored solutions. With 30+ years in industrial property, we combine personal support with proven expertise to create spaces that work for you.



HANDS-ON FACILITIES MANAGEMENT

Our in-house FM team provides tailored solutions—from reactive support and planned preventative maintenance to sustainable refurbishments. Tenants have direct access to experienced professionals who know the property and respond quickly to keep things running smoothly.

The background of the slide is a dark, architectural rendering of a modern industrial building. The building has a large, angular, cantilevered section on its right side. The PFI logo is visible on the upper right part of the building's facade. In the foreground, there is a road with a few blurred figures of people, including a cyclist and a person walking, suggesting a busy industrial or commercial area. The overall scene is dimly lit, possibly during dusk or dawn.

THANK YOU.

Contact:

Rodrigo Herring
Senior Development Manager
021 466 051
herring@pfi.co.nz

Michael Guptill-Bunce
Asset Manager
021 104 5550
guptillbunce@pfi.co.nz

www.pfi.co.nz

Property For Industry Limited
Level 4, Hayman Kronfeld Building
15 Galway Street
Auckland 1010

APPENDICES

- 1. BULK & LOCATION**
- 2. INDICATIVE OFFICE LAYOUT**
- 3. RACKING PLAN**



BULK & LOCATION.

01.



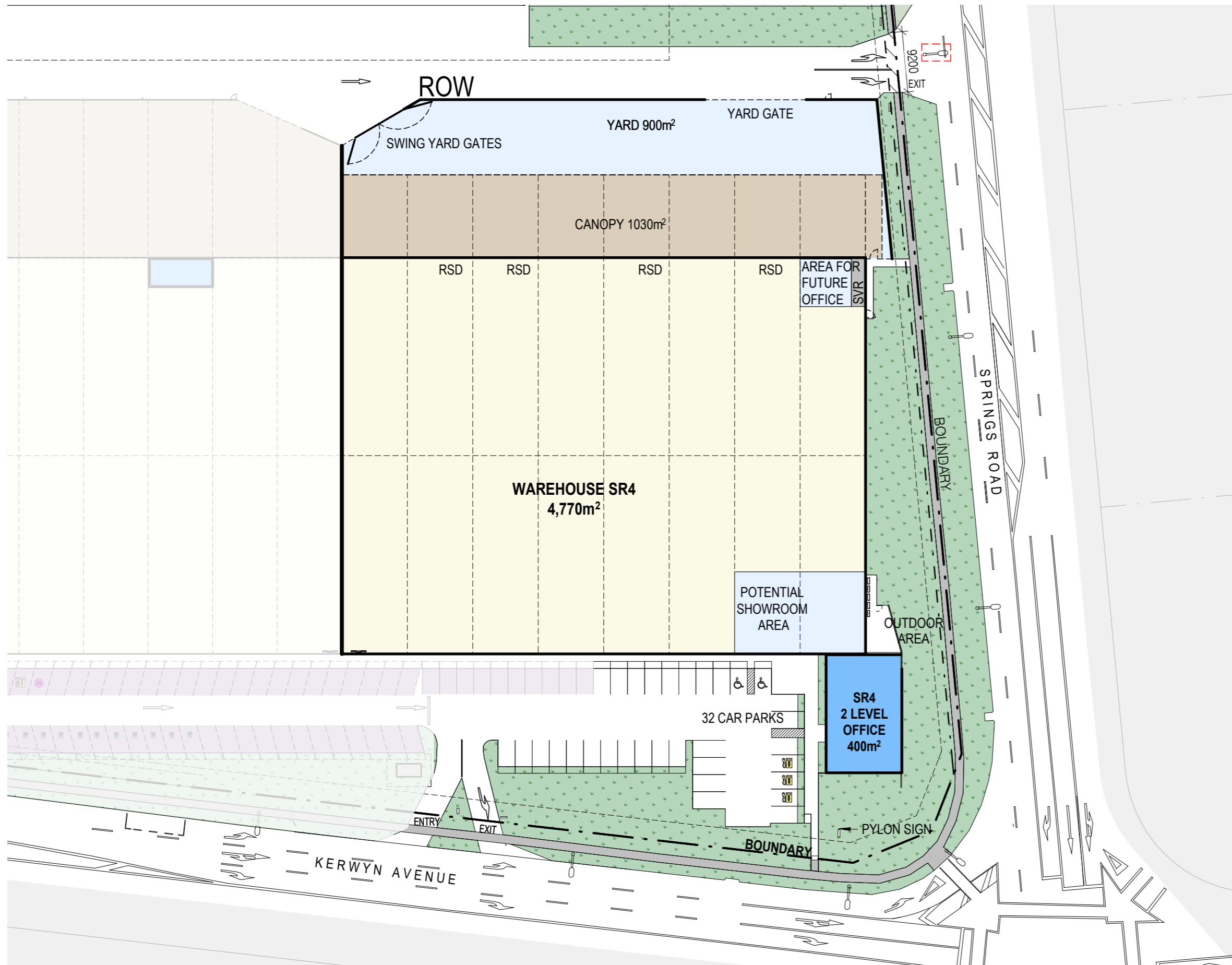

PROPOSED SR4 BUILDING GFA	
WAREHOUSE	4,770m ²
OFFICE TWO LEVELS	400m ²
CANOPIES - (NORTH)	1,030m ²
YARD - (NORTH)	900m ²

CARPARKS	
MAIN CARPARK SPACES	32

1
A19
PROPOSED SR4 B&L
1 : 600

INDICATIVE OFFICE LAYOUT.

02.





SR4 OFFICE GROUND FLOOR FURNITURE
A:SR4/23 T:50



SR4 OFFICE FIRST FLOOR FURNITURE
A:SR4/23 T:50

RACKING PLANS.

03.



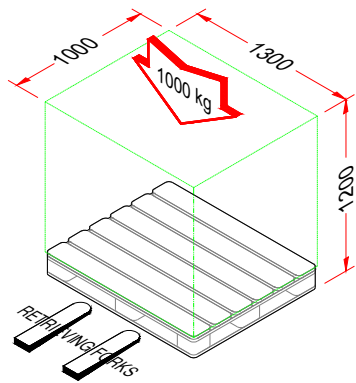

Type	Width	Depth	High	Weight	Total
Pallet	1200mm	1000mm	1300mm	1000kg	8,230

* **LOAD SIGN**

AON Advise on Alarm systems:
 For alarms relating to storage there is no required clearance.
 However, you need to keep in mind the when storing to the roof, storage may effectively create a wall.
 NZS 4512:2010 states that anything over 460mm is considered a wall. (storage pallets with product stored to roof could be considered as a wall)
 Any clearance is recommended to stop the above from happening.
 To be checked and confirmed by alarm contractor issuing PS3.

ISSUED FOR APPROVAL
 WE HAVE ASSUMED THE EXISTING SURFACE ONTO WHICH THIS INSTALLATION IS TO BE BUILT IS CAPABLE OF SUPPORTING THE STRUCTURAL AND ITS CONTENTS. WE RECOMMEND YOU OBTAIN INDEPENDENT VERIFICATION THAT THE EXISTING BUILDING IS CAPABLE OF SUSTAINING THE LOADS.
 DRAWING APPROVAL : _____
 APPROVED BY (SIGNATURE) : _____ DATE: _____

AUCKLAND RACKING & SHELVING
 Optimise your space, grow your business
 ADD: 56 Allens Road, East Tamaki, Auckland PH: 09 274 1939

PROPOSED RACKING LAYOUT
 PFI - PROPERTY FOR INDUSTRY NZ
 78 Springs Road, East Tamaki

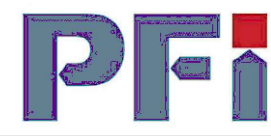

Rev	Description	By	Date
1	THIS DRAWING AND THE INFORMATION IT CONTAINS IS CONFIDENTIAL AND MUST NOT BE REPRODUCED, COPIED OR USED FOR ANY PURPOSE WITHOUT THE WRITTEN PERMISSION OF AUCKLAND RACKING AND SHELVING SOLUTIONS		
1	Drawn By : KB		Date : 10/10/2024
1	Checked By : JB		Paper Size : A3
1	Drawing No. : AR003776-01		Scale : NTS
1			Rev. No. : 0
1			Sht. No. : 1

PLAN 1

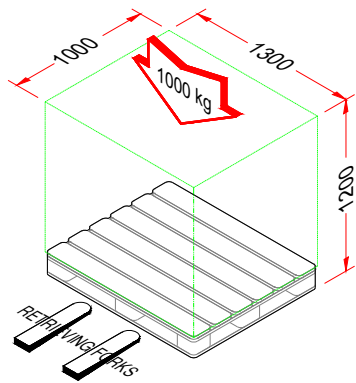

Design Summary - Plan 2					
Type	Width	Depth	High	Weight	Total
Pallet	1200mm	1000mm	1300mm	1000kg	10,506

* LOAD SIGN

AON Advise on Alarm systems:
For alarms relating to storage there is no required clearance.
However, you need to keep in mind the when storing to the roof, storage may effectively create a wall.
NZS 4512:2010 states that anything over 460mm is considered a wall. (storage pallets with product stored to roof could be considered as a wall)
Any clearance is recommended to stop the above from happening.
To be checked and confirmed by alarm contractor issuing PS3

ISSUED FOR APPROVAL
WE HAVE ASSUMED THE EXISTING SURFACE ONTO WHICH THIS INSTALLATION IS TO BE BUILT IS CAPABLE OF SUPPORTING THE STRUCTURAL AND ITS CONTENTS. WE RECOMMEND YOU OBTAIN INDEPENDENT VERIFICATION THAT THE EXISTING BUILDING IS CAPABLE OF SUSTAINING THE LOADS.
DRAWING APPROVAL : _____
APPROVED BY (SIGNATURE) : _____ DATE: _____

AUCKLAND RACKING & SHELVING
Optimise your space, grow your business
ADD: 56 Allens Road, East Tamaki, Auckland PH: 09 274 1939

PROPOSED RACKING LAYOUT
PFI - PROPERTY FOR INDUSTRY NZ
78 Springs Road, East Tamaki

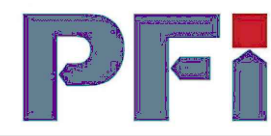

Rev	Description	By	Date
1	THIS DRAWING AND THE INFORMATION IT CONTAINS IS CONFIDENTIAL AND MUST NOT BE REPRODUCED, COPIED OR USED FOR ANY PURPOSE WITHOUT THE WRITTEN PERMISSION OF AUCKLAND RACKING AND SHELVING SOLUTIONS		
	Drawn By : KB		Date : 10/10/2024
	Checked By : JB		Paper Size : A3
	Drawing No. : AR003776-01		Scale : NTS
			Rev. No. : 0
			Sht. No. : 1

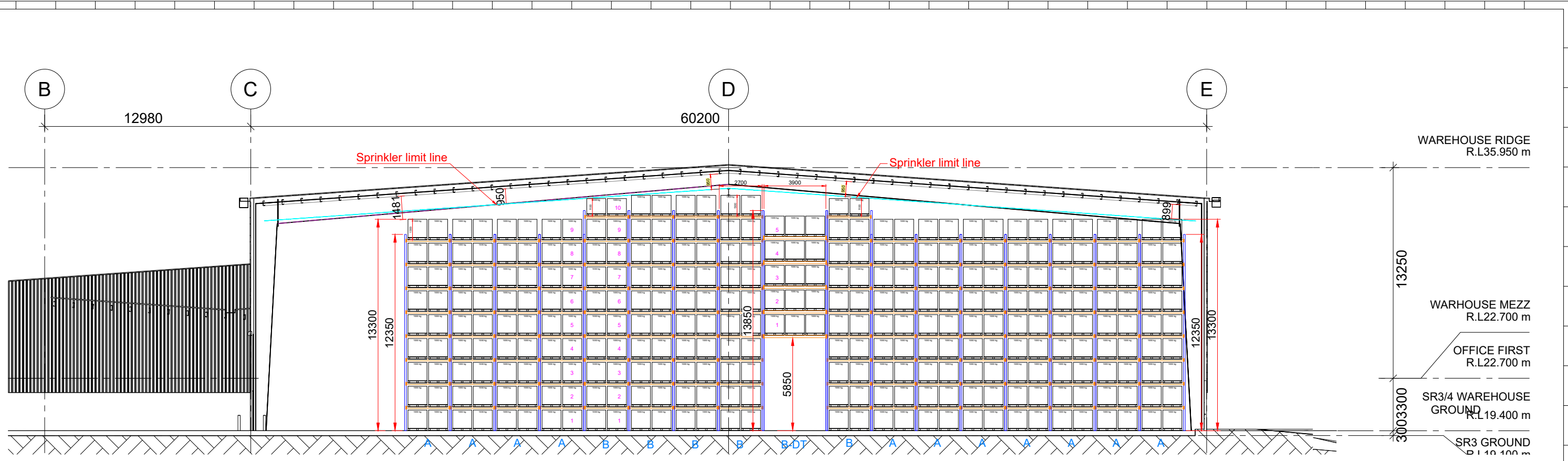

Section 1 for Plan 1

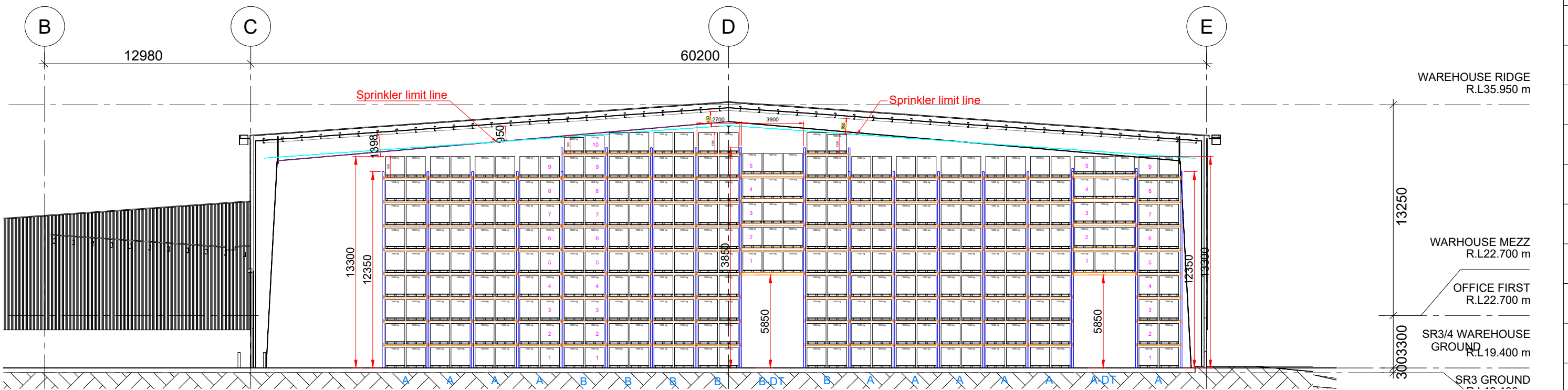

Section 2 for Plan 2

ISSUED FOR APPROVAL
 WE HAVE ASSUMED THE EXISTING SURFACE ONTO WHICH THIS INSTALLATION IS TO BE BUILT IS CAPABLE OF SUPPORTING THE STRUCTURAL AND ITS CONTENTS. WE RECOMMEND YOU OBTAIN INDEPENDENT VERIFICATION THAT THE EXISTING BUILDING IS CAPABLE OF SUSTAINING THE LOADS.
 DRAWING APPROVAL : _____
 APPROVED BY (SIGNATURE) : _____ DATE: _____

AUCKLAND RACKING & SHELVING
 Optimise your space, grow your business
 ADD: 56 Allens Road, East Tamaki, Auckland PH: 09 274 1939

PROPOSED RACKING LAYOUT
 PFI - PROPERTY FOR INDUSTRY NZ
 78 Springs Road, East Tamaki

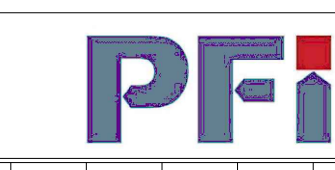

Rev	Description	By	Date
THIS DRAWING AND THE INFORMATION IT CONTAINS IS CONFIDENTIAL AND MUST NOT BE REPRODUCED, COPIED OR USED FOR ANY PURPOSE WITHOUT THE WRITTEN PERMISSION OF AUCKLAND RACKING AND SHELVING SOLUTIONS			
Drawn By :	KB	Date :	10/10/2024
Checked By :	JB	Paper Size :	A3
Drawing No. : AR003776-01		Scale :	NTS
		Rev. No. :	0
		Sht. No. :	1

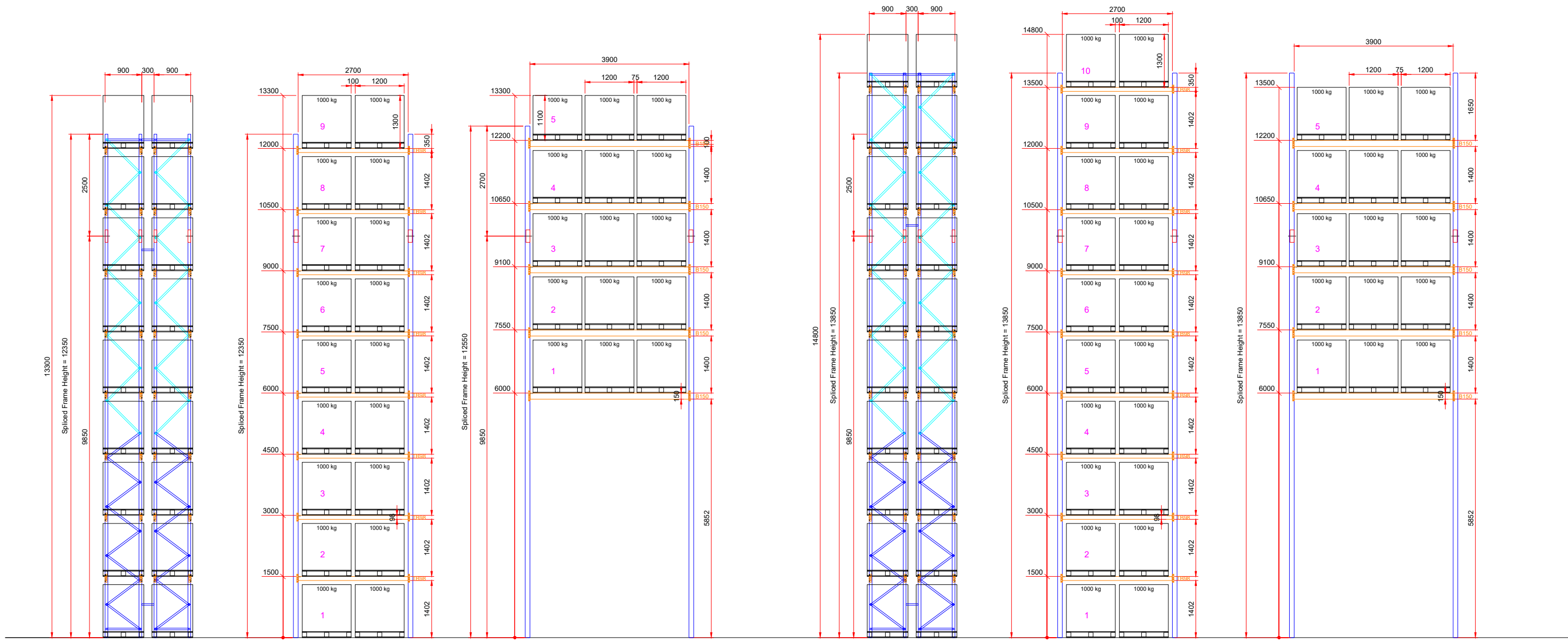

Rack Type A Side Elevation

Rack Type A Front Elevation

Rack Type A - Drive Thru Front Elevation

Rack Type B Side Elevation

Rack Type B Front Elevation

Rack Type B - Drive Thru Front Elevation

ELEVATION

ISSUED FOR APPROVAL
 WE HAVE ASSUMED THE EXISTING SURFACE ONTO WHICH THIS INSTALLATION IS TO BE BUILT IS CAPABLE OF SUPPORTING THE STRUCTURAL AND ITS CONTENTS. WE RECOMMEND YOU OBTAIN INDEPENDENT VERIFICATION THAT THE EXISTING BUILDING IS CAPABLE OF SUSTAINING THE LOADS.
 DRAWING APPROVAL : _____
 APPROVED BY (SIGNATURE) : _____ DATE : _____

AUCKLAND RACKING & SHELVING
 Optimise your space, grow your business
 ADD: 56 Allens Road, East Tamaki, Auckland PH: 09 274 1939

PROPOSED RACKING LAYOUT
 PFI - PROPERTY FOR INDUSTRY NZ
 78 Springs Road, East Tamaki



Rev	Description	By	Date
THIS DRAWING AND THE INFORMATION IT CONTAINS IS CONFIDENTIAL AND MUST NOT BE REPRODUCED, COPIED OR USED FOR ANY PURPOSE WITHOUT THE WRITTEN PERMISSION OF AUCKLAND RACKING AND SHELVING SOLUTIONS			
Drawn By :	KB	Date :	10/10/2024
Checked By :	JB	Paper Size :	A3
Drawing No. : AR003776-01		Scale :	NTS
		Rev. No. :	0
		Sht. No. :	1

This presentation was prepared by Property for Industry Limited (PFI) for the benefit and internal use of the named party and does not constitute a legally binding offer or agreement. PFI reserves the right to amend or withdraw any part of this proposal at any time prior to execution of a formal agreement.

This presentation contains confidential and proprietary information of PFI. It is intended solely for the use of the recipient for the purpose of evaluating this proposal and may not be disclosed to a third party without prior written consent of PFI.

This presentation is based on a number of preliminary assumptions regarding the named party's requirements as outlined in the RFP. This response is indicative only and subject to change [based on further discussions, due diligence and formal negotiations. Any changes to the scope, specifications, or requirements may result in adjustments to pricing, terms or timelines.] Whilst every care has been taken in relation to its accuracy, no warranty is given or implied and PFI accepts no liability for loss arising from the use of, the information in this presentation.

Images and/or plans contained in this document have been used to enable the named party to visualise the property and surrounding amenities only, and are not intended to definitively represent the final product.

All values are expressed in New Zealand currency and are exclusive of GST unless otherwise stated.